

# Little Oaks

YALDHURST

## **INTRODUCTION**

Gillman Wheelans Limited (GWL) have set in place a number of land covenants and rules that endure through the construction of dwellings, occupation and in specific instances, continue in perpetuity in the Little Oaks development, Yaldhurst. This is to ensure that we protect your housing investment in our developments.

The covenants offer you peace of mind in the knowledge that your neighbours are required to meet the same guidelines that protect both the built and landscape features and amenities of the area.

If we can be of further assistance in helping your design process, please contact us on (03) 963 1288.

## **ANCILLARY STRUCTURES**

All structures on the allotment within view of a Public Road, Right of Way or Access Lot shall be constructed of the same or consistent materials as the dwelling.

No fixtures, including storage of Gas or the installation of control equipment for gas or meter boxes visible on the street front elevation, shall be attached to the dwellings that in the opinion of GWL are obtrusive.

External antennae or satellite dishes shall be located on the side or rear of the dwelling however at all times shall be at least 7 metres from the road boundary.

## **ARCHITECTURAL FEATURES REQUIRED**

The following is a list of items or features that are encouraged to be included in the dwelling design. A minimum of three of the following list, or alternatives supplied by the applicant, should be included in the design to achieve the overall design anticipated in the development.

- 'Full Height' windows visible from the street other than where not possible due to joinery, etc.;
- Glazing in garages facing the street shall be opaque/obscure below a level of 1.5m.
- Solid Plaster or 'Bag Wash' finish;
- Skylights within the roof line;
- Linea Board or similar;
- Powder-coated Steelwork (Lattice) above entry or windows;
- External Shutters;
- Feature Chimney;
- Feature Front Doors and Handles;
- Portico or Porch, including associated columns and paving different from the driveway;

- Plastered or Brick Columns that are separate from previous item above;
- Boxed Window Sills on Plastered Dwellings;
- Landscape features such sculptures, water features, walls, planters retaining walls;
- Fencing and/or Gates between Dwelling and side Boundary (Paling fencing excluded).

## BOND REIMBURSEMENT

The following procedure must be adhered to in order to receive a refund of the bond in full.

- Developer approval and Council Consents are required prior to any work being undertaken on the site.
- Where fencing has not been erected by GWL, fencing shall be erected by the Purchaser prior to any site-works being undertaken.
- Where a driveway has not been constructed by GWL, the kerb is to be cut out, berm excavated and appropriate metal placed to ensure mud or other materials is not tracked onto roads with due care taken of irrigation lines.
- If coloured concrete or textured footpaths are removed for construction purposes, the driveway forward of the boundary shall match the surrounding footpath materials, colour and texture.
- The allotment is to be kept clean and tidy at all times with no materials windblown or otherwise from the site.
- No animals are permitted to 'wander' the site or adjoining sites.
- The driveways, pathways, letterbox and landscaping forward of the dwelling shall be completed prior to the occupation of the dwelling.
- Any damages caused outside of the allotment to be repaired immediately by the Purchaser or their contractors.

- GWL are to be notified of completion of the works to enable inspection prior to occupation.
- If the Protective Covenants and Special Conditions are complied with in all respects the Bond will be repaid in full and occupation may then occur.

Where the above procedure is not adhered to, GWL may recover the cost for repairs, correspondence and administration from the Bond prior to releasing it to the Purchaser. If occupation occurs prior to the Bond reimbursement request, the Bond may be forfeited.

## BUILDING HEIGHTS

Specific allotments will be chosen as suitable for either single or two storey dwellings whilst a number of allotments will be designated to have at least two storeys dwellings constructed thereon. The Protective Covenants will refer to such allotments and provide their allotment numbers.

In the design of a two-storey dwelling you should take into account the impact of upper storey windows and verandas on the privacy of your neighbours' private living and/or entertaining areas. Upstairs windows that impinge on neighbour's privacy should have corrective devices such as opaque/obscure glass or louvers/ shutters.

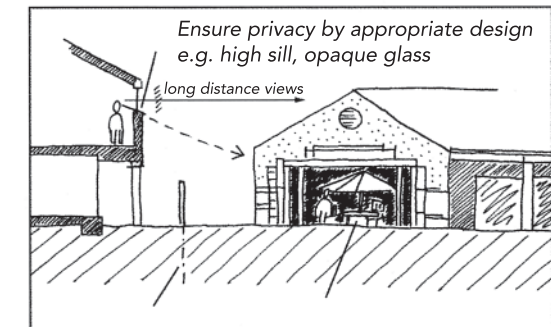

*Avoid infringement of neighbour's privacy*

## **BUILDING MATERIALS<sup>1</sup>**

Permitted roofing materials include tiles (clay, ceramic, concrete, decromastic, pre-coated pressed steel), cedar, slate or bitumen shingles or painted long-run pressed steel.

Permitted exterior materials include clay brick, recycled brick, stained or painted weatherboard, linea board, sealed concrete block masonry, natural stone, stucco, plaster, bag-wash, painted long-run pressed steel, glazing or any combination of the above.

Gutters and down pipes shall be pre-finished or painted to match the dwelling or the roof colour.

The use of unpainted zincalume roofing, gutters, downpipes or exterior cladding is not permitted.

## **BUILDING SIZES**

Each allotment has designated density range. This range is designated at the time of subdivision consent. Dwellings to be erected on each allotment shall have a minimum floor area based on the density range and lot area specified in line with the following<sup>2</sup>:

- High Density (A)  
at least 150m<sup>2</sup> (including minimum of single garage) under one roof;
- High Density (B)  
at least 165m<sup>2</sup> (including minimum of single garage) under one roof;
- Medium Density and being less than 620m<sup>2</sup>  
at least 180m<sup>2</sup> (including minimum of double garage) under one roof,
- Medium Density and being greater than or equal to 621m<sup>2</sup>  
at least 190m<sup>2</sup> (including minimum of double garage) under one roof.

## **BUILDING TIME**

Construction of dwellings on each site should commence within 24 months of possession of the land and the home should be complete within nine months of commencement of construction.

## **CONSENT NOTICES**

The Christchurch City Council or other authority may require Consent Notices to be attached to the title to be created by GWL. Consent Notices are typically used in the following situations.

- Restricting access to an allotment where any other access point, other than the prescribed location may be dangerous or inappropriate.
- As a requirement to complete specific site testing for ground bearing capacity for the dwelling being proposed.
- To notify the prospective allotment purchaser of the location of High Density allotments in the immediate vicinity.

## **DESIGN GUIDE**

To ensure the dwellings within the Little Oaks development are as innovative as the zone rules that apply to the development, GWL encourages a variety of designs and use of materials within the development. Building companies and architectural designers are set the challenge of designing around reduced setbacks, dwelling shapes and high-density living.

All housing, including terraced housing must be designed to address the street and neighbouring reserves, where visible from the reserve. Designs that do not achieve these results will not be acceptable.

The design must incorporate service areas that are not readily seen from public spaces to cater for washing lines, rubbish storage and collection, etc.

## DRIVEWAYS

Where a property frontage incorporates a public car park, landscaping, lighting or mounding, the location of the allotment access may be determined by GWL.

The berm and kerb crossing up to and including road metalling must be completed prior to construction of the dwelling. The driveway shall be completed prior to occupation of the dwelling.

Where a swale exists between the road and the allotment, the swale crossing shall be constructed in the location, manner and form directed by GWL and/or the appropriate local authority.

The driveway shall be paved it's full width i.e. no "car tracks" to a maximum width of 4.5m at the allotment boundary. The maximum width of 4.5m shall continue for a depth of 2.0m from the road boundary.

There should be at least 0.75m of screen planting or grass between driveways and side boundaries other than where the allotment is either High Density (A) or (B) & the dwelling utilizes a zero boundary building setback in which case the minimum separation is 0.25m. Refer picture.

Approved finishes for driveways include coloured stamped/stencilled or exposed aggregate concrete, asphaltic concrete, concrete cobblestones or pavers or similar. Where GWL constructs a kerb cut down and a driveway to an allotment, this access point should be used by the purchaser as the primary driveway entry. If the purchaser chooses to use

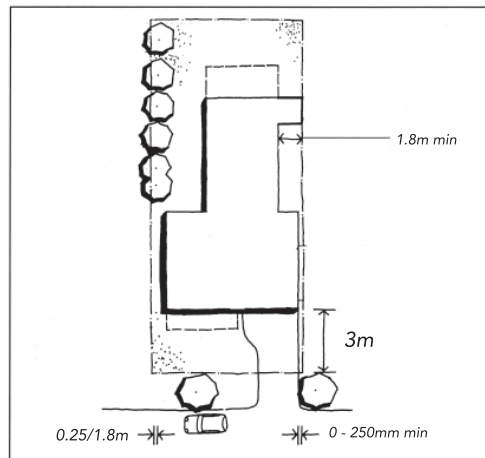

High density (A) and (B) allotments

an alternative location for a driveway, the existing driveway must be removed and made good at the cost of the purchaser in all respects.

The cost of such driveway within the public road reserve may be recoverable at the discretion of GWL to a maximum of the cost of a standard asphalt driveway. A schedule of expenditure for constructing asphalt driveways is at the rear of this information booklet.

## DWELLING PLAN APPROVAL PROCESS

To ensure that quality-housing standards are achieved, purchasers are required to obtain approval from GWL for any building works prior to making an application for building consent with the local authority.

A full set of dwelling plans, including landscape planes are to be supplied to GWL.

We will endeavour to process your plans, if the application is complete, within 5 working days of receipt of all the appropriate information.

A Bond of \$2,000 shall be paid by the Applicant at the time of making the application and that Bond will be held during the construction period.

No work on the site may occur without completing the approval process.

An incomplete application or non-complying application may be returned and processing fees applied at the discretion of GWL.

GWL in their sole discretion may decline approval of all or any part of the dwelling plans, even if the covenants have been met, if the plan is not in keeping with the standard of the development or proposed materials and finishes have been already been used too often within the development.

At the rear of this document is a Plan Approval Application that must be completed by the Applicant and supplied with the plans for approval.

## DWELLING SETBACKS

The setbacks in the Living G (Yaldhurst) Zone differ from other zones.

The setback from the road boundary has been reduced from the typical 4.5m to 3.0m however, where garages face the street, the minimum garage setback is retained at 5.5m from the street.

The front of the dwelling should be forward of the garage between 3.0m and 5.5m to 'address' the street. Refer Picture (1).

Setbacks from side boundaries in High Density (A) & (B) ranges have either been significantly reduced or removed altogether to assist in better utilization of outdoor spaces.

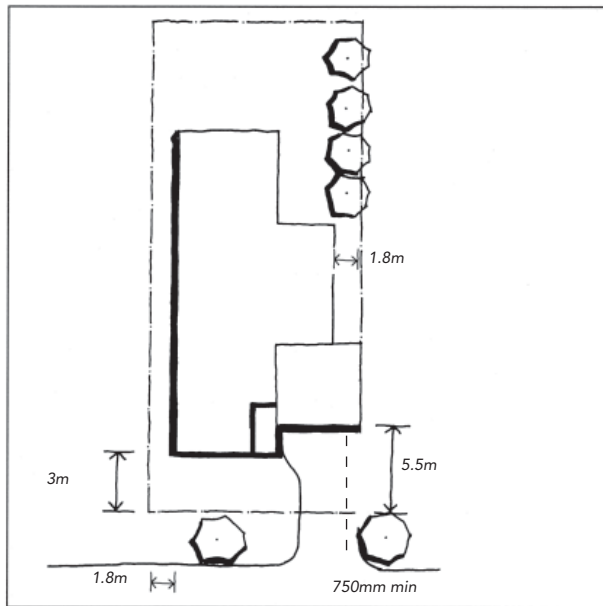

(1) Medium density allotment garage setback

Where a High Density allotment abuts a Medium or Low Density allotment, the lower density or more restrictive rules apply.

On some High Density sites on the north side of the road, the minimum setback may be reduced to 2 metres provided that specific conditions are met. Refer Pictures (2) & (3).

The parking of boats and other recreational vehicles should be screened from public view.

All purchasers and their designers should refer to these rules prior to commencing the dwelling design. Refer Pictures (4) & (5).

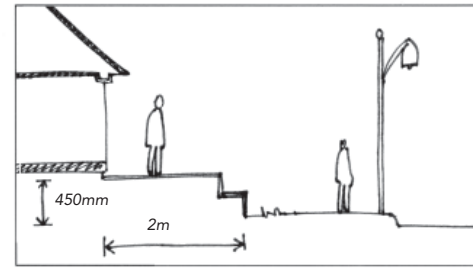

(2) High density allotment where setback reduced to 2m

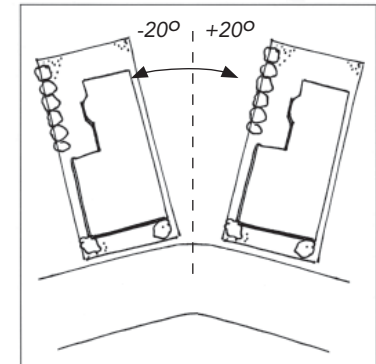

(3) High density allotment created + or - 20 degrees of true north

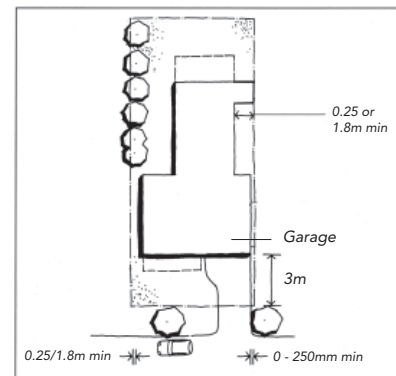

(4) High density (A) and (B) allotments

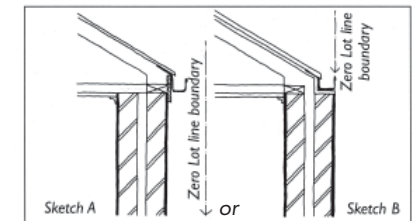

(5) Zero lot line boundary dwellings

## FENCING

### Fencing During Construction

All side and rear boundary fencing shall be completed prior to any building works commencing on site.

Temporary fencing (such as shade cloth or gates) to a height of not less than 1.8m is required on the road boundary during the construction period and shall be secured closed when construction is not occurring on the site (evenings, holidays, etc).

### Road Front Boundaries

Fencing will not be permitted within 2.0m of the road boundary except on High-Density allotments or allotments that have road frontage on two boundaries, where fencing on one road frontage may be permitted on the boundary<sup>3</sup>.

Street front fencing on lots designated as High Density is permitted on the road boundary subject to design approval by GWL with the design allowing for solid type no greater than 1.2m in height or palisade type fence no greater than 1.8m in height. Street front fencing on all dual frontage allotments shall be of similar materials to the dwelling. Such fencing shall be finished at least 1.0m behind the main building line (see above Picture).

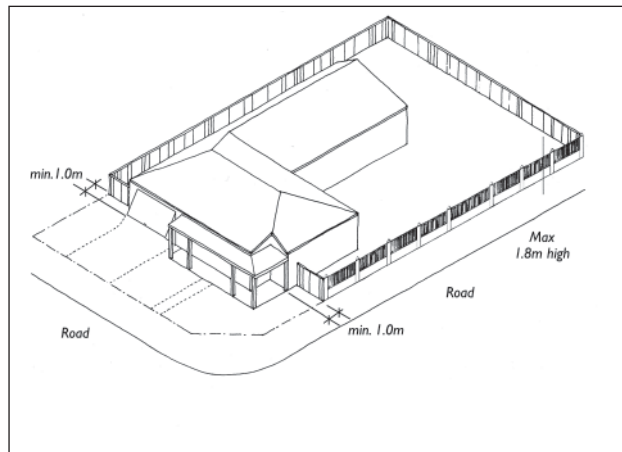

### Reserve & Rear Boundaries

Specifically designed fencing will be required on boundaries fronting a reserve (including 'future' road reserve) or where fences cross or adjoin a sculptured mound. Fencing fronting reserves shall be of 'open' style for a minimum of 50% of the reserve boundary.

Where fencing is erected by GWL on lots fronting a reserve or waterway, such fencing shall not be removed or altered without specific approval.

### Internal Boundaries

All internal boundary fences shall be constructed from masonry, solid timber or in the form of a paling fence with palings on the same side of the rails as the posts with timber capping, unless otherwise approved by GWL.

### General Fencing

No fencing shall be greater than 2.0m in height unless specifically approved by GWL. GWL shall retain the right to erect any side or rear boundary fencing of any allotment with a share of the cost of such fence payable by the Purchaser. GWL retains the right to erect boundary fencing on the public road boundary, reserve boundary or the boundary of any allotment prior to settlement particularly where access is restricted.

All Purchasers are liable to share the cost of all internal boundary fences including any fence that may have been erected by GWL or adjoining allotment owner.

GWL is not responsible to contribute to the cost of any fence where such fence has been erected by the Purchaser.

## **FURTHER SUBDIVISION**

On issue of titles for the individual allotments, no allotment may be further subdivided prior to 31st December 2012, unless specifically approved by GWL. Excluded from this are further stages of the planned subdivision by GWL.

## **GARAGES**

Double garages should be provided for on all allotments other than High Density (A) range allotments where alternatives will be considered, including single garages or parking being provided outside of the net allotment area.

Vehicle parking, garage doors and carport entranceways shall not comprise more than 50% of any ground floor elevation.

## **LANDSCAPING**

The Purchaser shall not remove or relocate any tree or shrub or any landscape feature within the front 2.0m of the allotment without the prior written consent of GWL.

No earthworks shall be undertaken whereby excavation or fill will exceed 0.75m from the present surface level of the property without approval.

The full length of the road frontage shall be landscaped to a depth of 2.0m except across those parts of the road boundary used as a vehicle or pedestrian crossing, or where necessary to ensure safety/visibility or security surveillance of public spaces.

Domestic driveways shall be a maximum width of 4.5m at the property boundary for a depth of at least 2m at the entrance (in order to facilitate landscaping) and allow clear visibility above 1m for a width of 1.5m either side of the entrance.

Landscaping visible from the road frontage shall be completed in accordance with the Landscape Plan prior to occupation of the dwelling.

## **MAINTENANCE**

Prior to, during, and after construction, the allotment is to be maintained in a clean and tidy manner. No excavation material, rubbish or builders waste shall be deposited on adjoining properties.

No rubbish, including Builders waste materials may accumulate or be placed on the allotment or any adjoining allotment.

Grass and/or weeds shall not be allowed grow to a height exceeding 75mm.

Should damage occur to landscaping, irrigation, berms and kerbs contained within the legal road reserve or any other allotment, either in front of, or adjacent to the Applicants allotment, the Purchaser shall immediately repair the damage.

GWL retains the right to remove any building materials from the allotment or any adjoining site or to maintain the site in a reasonable condition, that in their sole discretion, if left in their state, may be detrimental to the subdivision with reasonable costs to be met by the Purchaser.

## **OCCUPATION**

A dwelling may only be occupied by the Purchaser on completion of the works (including driveways, pathways, letterbox, landscaping and seeding of lawns visible from the boundary frontage) and once a Code Compliance Certificate has been issued by the local authority.

## **ON-SELLING**

In the event the Purchaser wishes to on-sell the allotment prior to settlement, the Purchaser must reserve, for the benefit of the Vendor, the Vendor's rights and the Purchaser's obligations as set out in Sale & Purchase Agreement and advise GWL immediately of the transaction.

## **ROOF PITCH**

A minimum roof pitch of 28 degrees will apply for all High Density (B) and Medium Density range housing<sup>4</sup>.

## **SHOW HOMES**

Show homes sites will be limited with the locations designated by GWL. Further show homes sites outside of the designated locations may be considered however will be subject to GWL approval. Consideration will be given to the number of sites being utilized for show purpose and GWL may in their sole discretion withhold consent for further show homes.

## **SIGNAGE**

Signage on individual allotments shall be limited to professionally sign written and installed signs marketing the dwelling or section for sale. The erection of signage indicating a business will only be permitted by GWL if such signage is acceptable in the sole discretion of GWL and prior written consent is obtained.

## **STORAGE OF LPG (LIQUID PETROLEUM GAS)**

The storage of LPG within an allotment shall be limited to 9kg bottles.

## **GENERAL**

GWL shall be permitted to provide adjoining allotment owners with the contact details to neighbouring allotments for the purposes of resource consent approvals, fencing notices and relevant communications.

The above covenants and rules apply to all Purchasers within developments undertaken by GWL. Where a Purchaser on-sells a section or a dwelling, it is the responsibility of that Purchaser to make subsequent Purchasers aware of these covenants and rules.

GWL reserves the right to alter or amend the Protective Covenants and Information Booklet for subsequent stages of Little Oaks.

The Purchaser covenants with GWL that they will not oppose or prevent GWL from progressing and completing Little Oaks or GWL's development plans or consents needed to generally give effect to the Little Oaks Development.

**PLAN APPROVAL APPLICATION**

This document must be completed by the applicant and supplied with the necessary information. If the appropriate information is not supplied the plans may be returned to the applicant and fees may be charged. GWL reserves the right to charge processing fees where any application requires significant input in achieving plan approval.

1. Owners Details \_\_\_\_\_  
Name of Applicant \_\_\_\_\_  
Allotment Owner (if different to above) \_\_\_\_\_  
Subdivision \_\_\_\_\_  
Stage of Subdivision \_\_\_\_\_  
Allotment Number \_\_\_\_\_  
Street Address of Allotment \_\_\_\_\_  
Current Postal Address of Applicant \_\_\_\_\_  
\_\_\_\_\_  
\_\_\_\_\_  
Phone Number of Applicant (Hm) \_\_\_\_\_ (Wk) \_\_\_\_\_ (Cell) \_\_\_\_\_  
Email address of Applicant \_\_\_\_\_

2. Builder/Architect Details \_\_\_\_\_  
Company Name \_\_\_\_\_  
Contact Name \_\_\_\_\_  
Postal Address \_\_\_\_\_  
\_\_\_\_\_  
Phone (Wk) \_\_\_\_\_ (Cell) \_\_\_\_\_  
Email address \_\_\_\_\_

3. House Details \_\_\_\_\_  
What is the Allotment Area m<sup>2</sup> \_\_\_\_\_  
What is the Floor Area of the dwelling (including garages, carport) m<sup>2</sup> \_\_\_\_\_  
What is the height of the Dwelling m \_\_\_\_\_  
What is the Roof Pitch of the Dwelling degrees \_\_\_\_\_  
How many levels is your dwelling (delete as req'd) single/two/three \_\_\_\_\_

4. Attachments

Included (please tick)

Please attach the following to your application:

- |   |   |
|---|---|
| <input type="checkbox"/> Site Plan                      | <input type="checkbox"/> Floor Plan                   |
| <input type="checkbox"/> Front Rear and Side Elevations | <input type="checkbox"/> Frontage Landscape Plan      |
| <input type="checkbox"/> Driveway Design                | <input type="checkbox"/> Fencing Detail (all sides)   |
| <input type="checkbox"/> Letterbox Location & Detail    | <input type="checkbox"/> Sectional/Timber Garage Door |
| <input type="checkbox"/> Four Optional Items            |   |

5. Exterior Materials & Colour scheme

Please provide colour samples with your application:

- Exterior Cladding
- Roof Cladding
- Colour Scheme
- Roof Colour
- Fascia Colour
- Wall Colour
- Joinery Colour
- Door Colour
- Garage Door Colour
- Driveway Materials & Colour

Office Use:

Date Application Received \_\_\_\_\_  
Date Bond Received \_\_\_\_\_  
Date Further Information Requested \_\_\_\_\_  
Date Further Information Received \_\_\_\_\_  
Date Approved \_\_\_\_\_  
Construction commenced \_\_\_\_\_  
Construction completed \_\_\_\_\_  
Bond Released (Date & Amount) \_\_\_\_\_

## **DISCLAIMER**

This document is a Summary of the Protective Covenants and Plan Approval process. The formal Protective Covenants are available on request. The Vendor takes no responsibility for the Purchaser relying on the above information when making their decision to purchase an allotment. The City Plan rules should be referred to in all circumstances.

## **IMPORTANT FOOTNOTES**

(Endnotes)

1. Alternative roofing materials and external cladding materials may be considered on their merits if in the opinion of GWL, those materials or claddings will not adversely effect the development. No zincalume finish materials are permitted unless a protective coatings has been applied over the zincalume.
2. Floor area measurements shall be based on the outside slab dimensions. Floor areas less than those specified may be accepted if the dwelling incorporates covered outdoor living area as a substitute to dwelling area. The allotment areas stated are net areas (exclusive of area of Access Lot, Right of Way or Driveway shared with any other Allotment or any area that is not zoned for residential purposes).
3. GWL retains the right to approve fencing within 2.0m of the road frontage due to the irregular shape, size or orientation of an individual allotment.
4. Alternative roof pitch may be considered on their merits if in the opinion of GWL, such pitch will not adversely effect the development.